

**EPSILON
CABLE**
The alternative

TESMEC
draw the way forward

HVCRC® STRINGING EQUIPMENT CATALOG



TESMEC, OUR MISSION:

OPERATE IN THE MARKET OF INFRASTRUCTURE FOR THE TRANSPORT OF ENERGY, DATA AND MATERIAL, FOR THE GROWTH AND MODERNIZATION OF EVERY COUNTRY IN THE WORLD.

Tesmec pursues a "Global" growth strategy: we are global, but at the same time we have a local presence in the most strategic areas of the world, in order to **meet the market's needs** in the best way.

Modern societies, as well as the emerging ones, face future challenges to invest in energy and telecommunications sectors.

New technologies can fill **the infrastructural gaps existing** between countries; these will improve the efficiency and the needs for future generations.

The need to rationalize energy costs and to improve the transmission speed of information, **makes the global investments** in energy and telecommunication sectors necessary for the global growth.

This is the reason why **Tesmec mission contemplates higher investments** in technologies for efficiency and management of grids. In its development strategy, Tesmec intends to consolidate the position of solution provider in the three business areas, exploiting the trends of the energy transition, digitalization, and sustainability.



ENERGY STRINGING

Machines and equipment for both overhead and underground stringing.

ENERGY AUTOMATION

Solutions for smart grids and automation systems.

TESMEC PRODUCT.

Tesmec designs, manufactures, and sells products, **technologies and integrated solutions** for the construction, maintenance and efficiency of infrastructures related to the transport and distribution of energy, data and material (oil and derivatives, gas, water).

In detail, the product portfolio consists of rock trenching equipment, surface miners, stringing equipment, railway equipment and electronic devices for smart grid management.

Tesmec, a pioneer in stringing solutions, faces the challenge of combining a strong tradition of **quality, reliability and durability** with a new concept of integrated, digital and sustainable solutions.

Tesmec designs and develops high performance stringing machines and equipments to provide customers with affordable solutions based on the latest technology.

The new range of **Digital Machines embraces new technologies** without compromising the strong tradition of quality, reliability and durability that distinguishes Tesmec products.

The R&D Department works to **improve stringing methodologies**, developing the construction site of the future, guaranteeing time and cost savings and the highest level of safety.

and maintenance of energy transport and distribution infrastructures.



TRENCHERS & SURFACE MINERS

Solutions excavation of trenches, laying of sub-services and cultivation of surface mines.



RAILWAY

Installation, maintenance and diagnostics of the railway line.

EPSILON CABLE, OUR MISSION:

WE DESIGN AND MANUFACTURE ADVANCED CONDUCTORS TO MODERNIZE POWER LINES WORLDWIDE.

Since 1987, Epsilon is a **pioneer and world leader** in high performance composite materials thanks to the pultrusion process.

This highly efficient technology, combined with the extraordinary properties of carbon fibers makes the perfect solution to manufacture strong durable **composite cores for advanced conductors**, also known as High Temperature Low Sag (HTLS) conductors.

This new generation of conductors is successfully being used worldwide to increase ampacity, reduce sag and electrical losses.

Epsilon Cable is at the forefront of this grid modernization, with a proven track record of several **thousands of kilometers of conductors** installed worldwide.

With its R&D center and Pultrusion facilities in France, Epsilon is ISO 9001 certified and supplies the most demanding cable manufacturers and EPCs to help them meet utilities' ambitious performance & cost targets on reconductoring projects as well as new lines.

Epsilon Cable and its partners developed the **HVCRC® conductor range** (with composite cores qualified according to ASTM B987), along with the necessary hardware and support for design, installation and maintenance.



Epsilon Cable composite cores for advanced conductors

INSTALLATION SUPPORT.

Our experts can train installation teams worldwide, and provide onsite **assistance and supervision** during installation.

Even though HVCRC® conductors use standard compression accessories and methods, they **require some basic care and training** to avoid any issue, such as damaging the structural composite core.

In our experience, proper installation methods with quality tools and machines are a key factor in the success of a project and ensure the optimal durability of conductors! That is why, Epsilon Cable is very proud to have this catalogue with Tesmec as both companies **share the same taste for quality and innovation**.

Requirement for bull wheel dimension is to have a diameter being minimum at 170 times the composite core diameter (or 180 times for the HVCRC® ULS range)

Grooves with hard surface have no influence on the conductor because the contact pressure between them and the conductor is lower than the internal pressure between elementary wires of the conductor.

Moreover, low friction involves self-alignment of the conductor on the bottom of the groove and has no influence related to the right-hand or left-hand formation of the conductor; the main consequence is that **machines are simple to use** and the conductor loading procedure is faster than before. The benefit of the harder material applied for years to traditional conductors is even more evident.

In such situation, machines with **hard material grooves** are the optimal solution, because the low friction minimizes the torsional overstress on the conductor and allows a smooth and regular stringing operation, thus preserving the conductor integrity.

HVCRC® conductor stringing requirement has been reflected into the design of stringing machines by requesting larger bull wheels compared to traditional ACSR stringing procedure. Only multi-groove machines and a minimum of four grooves should be used. Material applied for years to traditional conductors is even more evident.

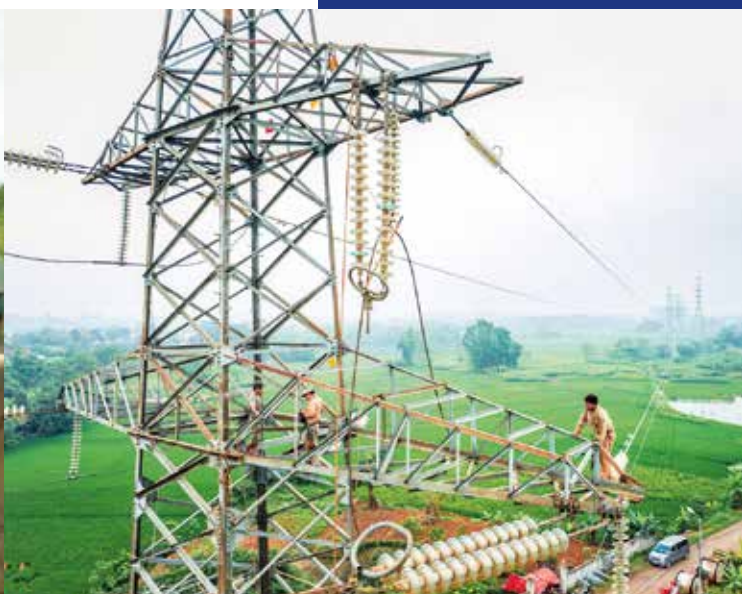
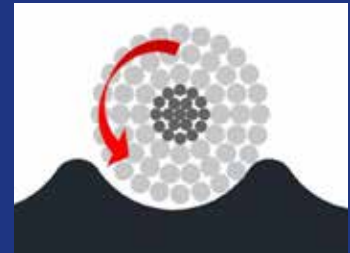
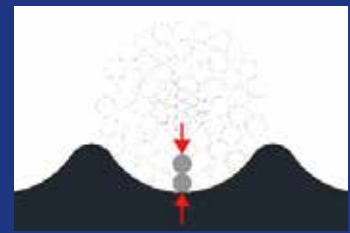

TESMEC TECHNOLOGY

In order to anchor HVCRC® conductors, one needs to pay attention to midspan joints and dead ends compression procedure. To ease this operation, the light and handy 100 tons compressor unit, **weighting only 34 kg**, is perfectly suited.

Simple and compact, double-acting hydraulic integrated distributor. With this flexible innovative solution, it is possible to use existing fleet of dies. Dies can be interchanged just by pushing a button without using any tools.

This tool was designed having in mind two target features, **namely ease of use and handling**. The press is made of high resistance forged steel in cylindrical shape to provide an ideal strength/weight ratio, which has been increased considerably to offer the lightest equipment possible.

Products already deployed have shown no issue after 25.000 cycles.

The datasheet below emphasizes on the main features of the tool.

It can accommodate different dies and custom ones **can be manufactured on request**.

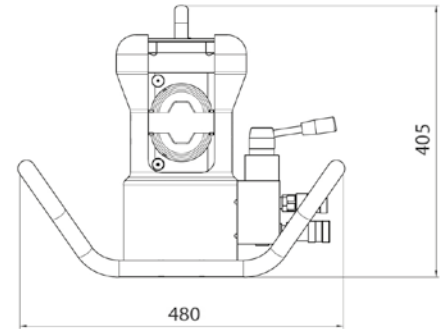

Technical specifications

Max compression force	1000 kN
Max pressure	700 bar
Max hexagon "ch" for steel	29 mm
Max hexagon "ch" for aluminium	60 mm
Max stroke	31 mm
Compressor mass	34.5 kg
Die mass	2 kg
Dimensions (bxlxh)	480 mm 255 mm 405 mm

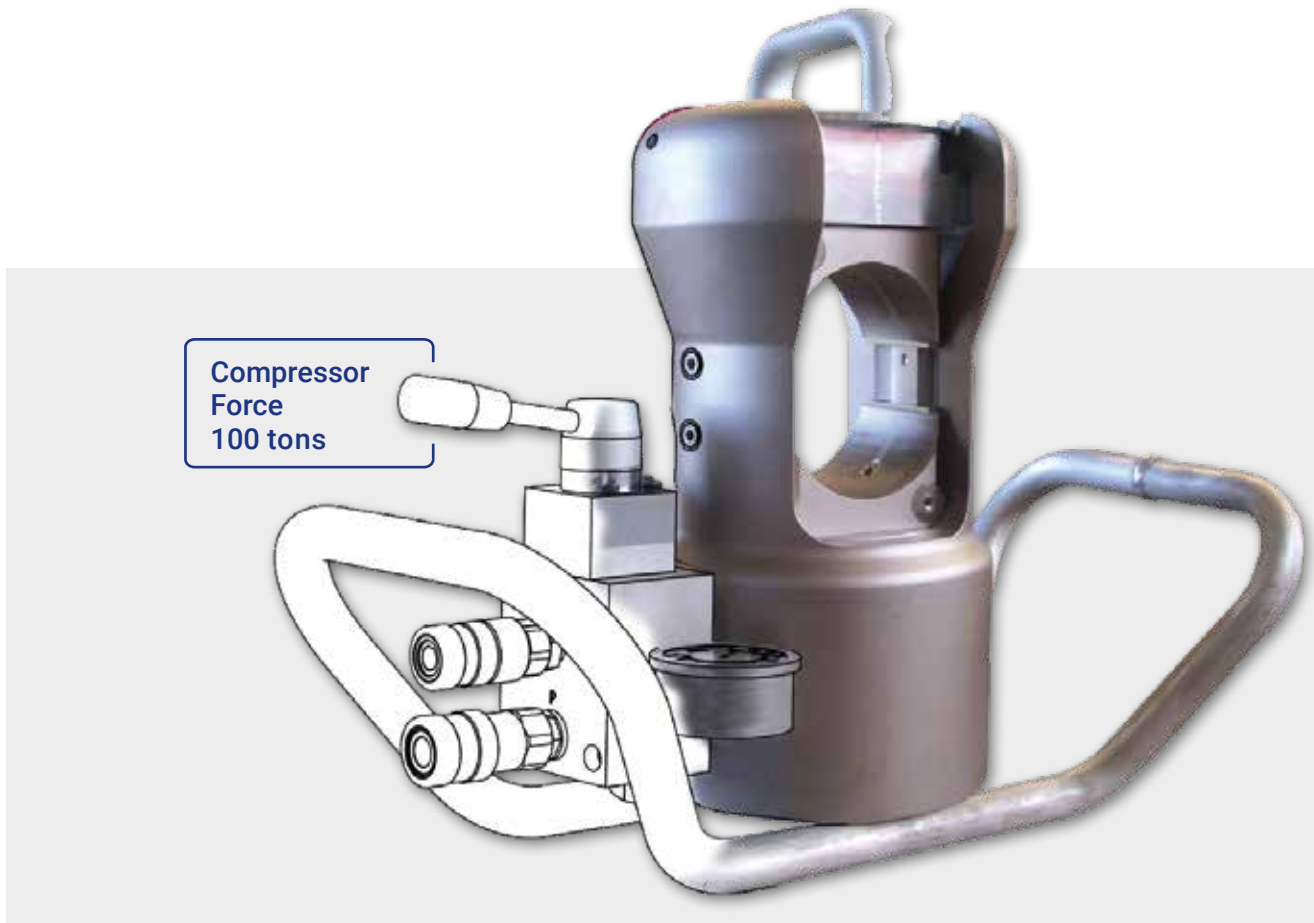

Tesmec is committed in new technologies

While laying HVCRC® conductors, it is of the utmost importance to control the quality of the pulling rope. Its main purpose is **to pull the conductor without creating overstresses** or bird caging.

At stake is the risk to damage the conductor, and subsequently have to replace it entirely. Tesmec provides ropes that have been developed accordingly.

To grant the **best safety level**, Tesmec has developed a rope not based on diameter measurements but rather working on load ranges, which yields higher safety levels.

The other important feature of this rope is its anti-twisting capability.

HVCRC® conductor cores can **withstand great tension stresses** but are more sensitive to torsional stresses. For this reason, having an anti-twisting rope that can mitigate or eliminate these stresses is of fundamental importance.

Tesmec is committed in new technologies, aiming at delivering the best machines and tools to ease the job, make it more efficient and safer.

In the past years the investments and the focus for this field has increased greatly. New testing machines has been added to the quality laboratory and all the equipment (machines or accessories) that are delivered to customers, are **tested with long run tests**, and validated following a strict quality procedure.

In addition, Tesmec rope offers the following advantages:

- **Steel quality:** at the same time very strong and flexible
- **Flexibility:** more flexible than any other rope available on the market
- **Elongation:** lower than 2.5% to avoid spring effect and conductor damage
- **Galvanizing:** high resistance to corrosion thanks to galvanizing process of each elementary wire
- **Greasing:** the strands are greased one by one ensuring much longer lubrication effect
- **Special length:** available without joints or connectors
- **Life cycle:** longer than any other rope on the market, up to ten years or more



PULLER CAPACITY
es. 50 kN

X

SAFETY
FACTOR 3

=

ROPE BREAKING
LOAD es. 150 kN



TESMEC TEST SITE

During the design phase, the testing laboratory provides the first feedback for the outcome of a tool or machine.

In particular, Tesmec external testing field has the capability to run tests **simultaneously on 4 machines** (either puller, tensioner or puller tensioner). In addition, Tesmec owns a test bench to assess the strength of the rope and the gripping of the installation clamps.

This machine has been used to test the behavior of Tesmec self-gripping clamps on Epsilon HVCRC® conductors (report is available upon request).

For pulleys, array blocks, aluminum structure and other tools, **Tesmec developed a tailored bench** which gives to ability to perform several tests to verify the working load, the braking load and simulate fatigue stresses.

Together with the equipment, ropes and conductors can be tested, simulating bending stress.

“ Tesmec owns a test bench to assess the strength of the rope and the gripping of the installation clamps. ”



Reference	International size	ASTM	Outer Ø (mm)	Core Ø (mm)	min. Bullwheels Ø (mm)	min. N° Grooves	Liners Material
HVCRC 130-28	SILVASSA	-	14,35	5,97	1500	4	Nyatron®/ Steel
HVCRC 160-28	HELSINKI	PASADENA	15,65	5,97	1500	4	Nyatron®/ Steel
HVCRC 160-47	JAIPUR	-	16,51	7,75	1500	4	Nyatron®/ Steel
HVCRC 160-18	BERN	-	15,5	4,82	1500	4	Nyatron®/ Steel
HVCRC 180-40	ZADAR	-	17,09	7,11	1500	4	Nyatron®/ Steel
HVCRC 190-28	ROVINJ	-	17,09	5,97	1500	4	Nyatron®/ Steel
HVCRC 230-28	COPENHAGEN	LINNET	18,29	5,97	1500	4	Nyatron®/ Steel
HVCRC 230-40	REYKJAVIK	ORIOLE	18,82	7,11	1500	4	Nyatron®/ Steel
HVCRC 230-87	MONTE CARLO	-	20,78	10,54	1800	4	Nyatron®/ Steel
HVCRC 240-47	GLASGOW	WACO	19,55	7,75	1500	4	Nyatron®/ Steel
HVCRC 250-28	GDANSK	-	19,21	5,97	1500	4	Nyatron®/ Steel
HVCRC 280-40	CASABLANCA	LAREDO	20,51	7,11	1500	4	Nyatron®/ Steel
HVCRC 320-47	OSLO	IRVING	22,4	8,76	1500÷1800	4	Nyatron®/ Steel
HVCRC 320-40	LISBON	HAWK	21,79	7,11	1500	4	Nyatron®/ Steel
HVCRC 370-47	AMSTERDAM	DOVE	23,55	7,75	1500	4	Nyatron®/ Steel
HVCRC 410-47	CORDOBA	-	24,43	7,75	1500	4	Nyatron®/ Steel
HVCRC 430-52	BRUSSELS	GROSEBEAK	25,13	8,13	1500÷1800	5	Nyatron®/ Steel
HVCRC 470-60	STOCKHOLM	LUBBOCK	26,4	8,76	1500÷1800	5	Nyatron®/ Steel
HVCRC 520-60	WARSAW	CUCKOO	27,72	8,76	1500÷1800	5	Nyatron®/ Steel
HVCRC 530-71	DUBLIN	DRAKE	28,17	9,53	1800	5	Nyatron®/ Steel
HVCRC 560-60	HAMBURG	PLANO	28,62	8,76	1500÷1800	5	Nyatron®/ Steel
HVCRC 580-60	MILAN	CORPUS CHRISTI	29,1	8,76	1500÷1800	5	Nyatron®/ Steel
HVCRC 600-71	ROME	ARLINGTON	29,87	9,53	1800	5	Nyatron®/ Steel
HVCRC 640-60	VIENNA	CARDINAL	30,42	8,76	1500÷1800	5	Nyatron®/ Steel
HVCRC 680-71	BUDAPEST	FORT WORTH	31,49	9,53	1800	5	Nyatron®/ Steel
HVCRC 700-60	PRAGUE	EL PASO	31,8	8,76	1500÷1800	5	Nyatron®/ Steel
HVCRC 740-71	MUNICH	BEAUMONT	32,87	9,53	1800	5	Nyatron®/ Steel
HVCRC 750-87	WARWICK	-	33,4	10,54	1800	5	Nyatron®/ Steel
HVCRC 770-75	LONDON	SAN ANTONIO	33,42	9,78	1800	5	Nyatron®/ Steel
HVCRC 820-60	PARIS	BITTERN	34,2	8,76	1500÷1800	5	Nyatron®/ Steel
HVCRC 880-87	BORDEAUX	-	35,76	10,54	1800	5	Nyatron®/ Steel
HVCRC 950-75	ANTWERP	DALLAS	36,9	9,78	1800	5	Nyatron®/ Steel
HVCRC 1020-75	MADRID	LAPWING	38,18	9,78	1800	5	Nyatron®/ Steel
HVCRC 1160-79	CHUKAR	CHUKAR	40,74	10,03	1800	5	Nyatron®/ Steel

NEW CONCEPT MACHINES.

TESMEC INTRODUCES REVOLUTIONARY STRINGING MACHINES, DESIGNED FOR THE FUTURE. A STRONG TRADITION OF QUALITY, RELIABILITY AND DURABILITY MEETS THE NEW TECHNOLOGIES GENERATING A NEW CONCEPT OF MACHINES.

Tesmec new digital 4.0 machines are perfectly suitable for the stringing of new generation conductors.

A strong tradition of quality, reliability and durability meets the new technologies generating a customized product. Machines for stringing HVCRC® conductors benefit from the state-of-the-art technology of the traditional machines.

Bigger bull wheels are considered to avoid conductor damage, reducing the friction and the possible wear between the two contact surfaces.

Different material, nylon, or aluminum, allow to choose the best solution for the cable to be strung.

The unique hydraulic circuit combined with the latest technologies, grants a perfect managing of the machine preventing any possibility of damaging the conductor.



THE NEW DIGITAL STRINGING MACHINES ARE



USER FRIENDLY



SAFE



RELIABLE

HELICOPTER MACHINE

The new tensioner for helicopter stringing is the most advanced Tesmec technology.

It ensures the best performance in the “direct stringing” by helicopter, where the puller is replaced by the helicopter itself and it includes lot of sub technologies and features that make this machine the safest possible for such operations.

Three registered patents are pending on this product:

- + Unit for winding and unwinding cables.
- + Cable-laying apparatus provided with a safety system, and method, for stopping safely.
- + Special safety device.

REMOTE CONTROL

The remote, also usable by cable connection, controls the machine and allows the operator to work from a position that offers a better overview of the jobsite, less noise and a higher degree of safety.



NEW HUMAN INTERFACE (HMI)

The new control panel is drastically simplified. The innovative graphic display shows all the information, including diesel engine parameters, machine performance, and diagnostic output.



Reference	International size	ASTM	Outer Ø (mm)	Core Ø (mm)	Suggested Sheave (mm)	Min. groove width (mm)	Layout	Liners Material
HVCRC 130-28	SILVASSA	-	14,35	5,97	Pulley Block (Ø650)	68 (Narrow)	Single	Nyatron®/Aluminium
HVCRC 160-28	HELSENKI	PASADENA	15,65	5,97	Pulley Block (Ø650)	68 (Narrow)	Single	Nyatron®/Aluminium
HVCRC 160-47	JAIPUR	.	16,51	7,75	Pulley Block (Ø800)	68 (Narrow)	Single	Nyatron®/Aluminium
HVCRC 160-18	BERN	-	15,5	4,82	Pulley Block (Ø650)	68 (Narrow)	Single	Nyatron®/Aluminium
HVCRC 180-40	ZADAR	-	17,09	7,11	Pulley Block (Ø800)	95 (Wide)	Single	Nyatron®/Aluminium
HVCRC 190-28	ROVINJ	-	17,09	5,97	Pulley Block (Ø650)	68 (Narrow)	Single	Nyatron®/Aluminium
HVCRC 230-28	COPENHAGEN	LINNET	18,29	5,97	Pulley Block (Ø650)	68 (Narrow)	Single	Nyatron®/Aluminium
HVCRC 230-40	REYKJAVIK	ORIOLE	18,82	7,11	Pulley Block (Ø800)	95 (Wide)	Single	Nyatron®/Aluminium
HVCRC 230-87	MONTE CARLO	-	20,78	10,54	Pivoting Array Block (eq.Ø1890)	95 (Wide)	Single - Three Bundle	Fiberglass Nyatron®/Aluminium
HVCRC 240-47	GLASGOW	WACO	19,55	7,75	Pulley Block (Ø800)	95 (Wide)	Single - Three Bundle	Nyatron®/Aluminium
HVCRC 250-28	GDANSK	-	19,21	5,97	Pulley Block (Ø650)	68 (Narrow)	Single - Three Bundle	Nyatron®/Aluminium
HVCRC 280-40	CASABLANCA	LAREDO	20,51	7,11	Pulley Block (Ø800)	95 (Wide)	Single - Three Bundle	Nyatron®/Aluminium
HVCRC 320-47	OSLO	IRVING	22,4	8,76	Pivoting Array Block (eq.Ø1890)	95 (Wide)	Single - Three Bundle	Fiberglass Nyatron®/Aluminium
HVCRC 320-40	LISBON	HAWK	21,79	7,11	Pulley Block (Ø800)	95 (Wide)	Single - Three Bundle	Nyatron®/Aluminium
HVCRC 370-47	AMSTERDAM	DOVE	23,55	7,75	Pulley Block (Ø800)	95 (Wide)	Single - Three Bundle	Nyatron®/Aluminium
HVCRC 410-47	CORDOBA	-	24,43	7,75	Pulley Block (Ø800)	68 (Narrow)	Single - Three Bundle	Nyatron®/Aluminium
HVCRC 430-52	BRUSSELS	GROESBEAK	25,13	8,13	Pivoting Array Block (eq.Ø1890)	95 (Wide)	Three/Four Bundle	Fiberglass Nyatron®/Aluminium
HVCRC 470-60	STOCKHOLM	LUBBOCK	26,4	8,76	Pivoting Array Block (eq.Ø1890)	95 (Wide)	Three/Four Bundle	Fiberglass Nyatron®/Aluminium
HVCRC 520-60	WARSAW	CUCKOO	27,72	8,76	Pivoting Array Block (eq.Ø1890)	95 (Wide)	Three/Four Bundle	Fiberglass Nyatron®/Aluminium
HVCRC 530-71	DUBLIN	DRAKE	28,17	9,53	Pivoting Array Block (eq.Ø1890)	95 (Wide)	Three/Four Bundle	Fiberglass Nyatron®/Aluminium
HVCRC 560-60	HAMBURG	PLANO	28,62	8,76	Pivoting Array Block (eq.Ø1890)	95 (Wide)	Three/Four Bundle	Fiberglass Nyatron®/Aluminium
HVCRC 580-60	MILAN	CORRUS CRISTI	29,1	8,76	Pivoting Array Block (eq.Ø1890)	95 (Wide)	Three/Four Bundle	Fiberglass Nyatron®/Aluminium
HVCRC 600-71	ROME	ARLINGTON	29,87	9,53	Pivoting Array Block (eq.Ø1890)	95 (Wide)	Three/Four Bundle	Fiberglass Nyatron®/Aluminium
HVCRC 640-60	VIENNA	CARDINAL	30,42	8,76	Pivoting Array Block (eq.Ø1890)	95 (Wide)	Three/Four Bundle	Fiberglass Nyatron®/Aluminium
HVCRC 680-71	BUDAPEST	FORT WORTH	31,49	9,53	Pivoting Array Block (eq.Ø1890)	95 (Wide)	Three/Four Bundle	Fiberglass Nyatron®/Aluminium
HVCRC 700-60	PRAGUE	EL PASO	31,8	8,76	Pivoting Array Block (eq.Ø1890)	95 (Wide)	Three/Four Bundle	Fiberglass Nyatron®/Aluminium
HVCRC 740-71	MUNICH	BEAUMONT	32,87	9,53	Pivoting Array Block (eq.Ø1890)	95 (Wide)	Three/Four Bundle	Fiberglass Nyatron®/Aluminium
HVCRC 750-87	WARWICK	-	33,4	10,54	Pivoting Array Block (eq.Ø1890)	95 (Wide)	Three/Four Bundle	Fiberglass Nyatron®/Aluminium
HVCRC 770-75	LONDON	SAN ANTONIO	33,42	9,78	Pivoting Array Block (eq.Ø1890)	95 (Wide)	Three/Four Bundle	Fiberglass Nyatron®/Aluminium
HVCRC 820-60	PARIS	BITTERN	34,2	8,76	Pivoting Array Block (eq.Ø1890)	95 (Wide)	Three/Four Bundle	Fiberglass Nyatron®/Aluminium
HVCRC 880-87	BORDEAUX	-	35,76	10,54	Pivoting Array Block (eq.Ø1890)	95 (Wide)	Three/Four Bundle	Fiberglass Nyatron®/Aluminium
HVCRC 950-75	ANTWERP	DALLAS	36,9	9,78	Pivoting Array Block (eq.Ø1890)	95 (Wide)	Three/Four Bundle	Fiberglass Nyatron®/Aluminium
HVCRC 1020-75	MADRID	LAPWING	38,18	9,78	Pivoting Array Block (eq.Ø1890)	95 (Wide)	Three/Four Bundle	Fiberglass Nyatron®/Aluminium
HVCRC 1160-79	CHUKAR	CHUKAR	40,74	10,03	Pivoting Array Block (eq.Ø1890)	95 (Wide)	Three/Four Bundle	Fiberglass Nyatron®/Aluminium

TESMEC HAS MORE THAN 70 YEARS OF EXPERIENCE TESTED ON JOBSITE.

Thanks to this extensive knowledge it is possible to choose from many solutions regarding stringing blocks.

Tesmec offers a complete range that includes standard stringing blocks, detachable and tandem devices.

Different tailor-made solutions are also available, from single conductor to bundle conductor and up to six, many types of liners material and shape, wheels diameter and much more to adapt perfectly to the jobsite needs, especially for new generation HVCRC® conductors.



PIVOTING ARRAY BLOCKS

Array blocks are the solution when large bending radius is needed. In fact, with such solution you do not have any diameter limitation. This item has been developed keeping dimension, weight, and handling capability as easy as possible.

As for the standard blocks it is possible to choose different shape of groove, and different materials.

They are fully matchable with standard blocks and thanks to a higher center of gravity they have a better handling. Integrated earthing device available as an option.



BLOCKS FOR HELICOPTER STRINGING

Special models of pulley blocks are available for stringing operations made by helicopter, a special guide ensure the correct positioning of the rope or the conductor during stringing operation.

Wheels are made of lightweight aluminum and groove liners are easily interchangeable and made of nylon or other materials on request. It is possible to choose different shape of groove, and different diameter of wheel. Integrated earthing device available as an option.

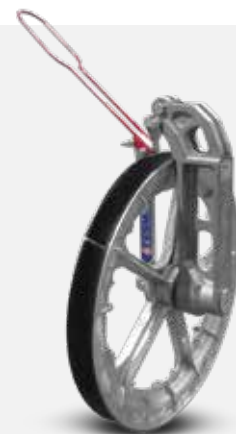

Reference	International size	ASTM	Outer Ø (mm)	Core Ø (mm)	Self gripping clamp model	Jaws model	Socket joint single (double end)
HVCRC 130-28	SILVASSA	-	14,35	5,97	MOT130GC	GTJ116	GCT001 (GCT500)
HVCRC 160-28	HELSINKI	PASADENA	15,65	5,97	MOT130GC	GTJ116	GCT001 (GCT500)
HVCRC 160-47	JAIPIUR	-	16,51	7,75	MOT150GC	GTJ117	GCT001 (GCT500)
HVCRC 160-18	BERN	-	15,5	4,82	MOT150GC	GTJ117	GCT001 (GCT500)
HVCRC 180-40	ZADAR	-	17,09	7,11	MOT150GC	GTJ120	GCT010 (GCT510)
HVCRC 190-28	ROVINJ	-	17,09	5,97	MOT150GC	GTJ120	GCT010 (GCT510)
HVCRC 230-28	COPENHAGEN	LINNET	18,29	5,97	MOT150GC	GTJ120	GCT010 (GCT510)
HVCRC 230-40	REYKJAVIK	ORIOLE	18,82	7,11	MOT150GC	GTJ120	GCT010 (GCT510)
HVCRC 230-87	MONTE CARLO	-	20,78	10,54	MOT150GC	GTJ123	GCT010 (GCT510)
HVCRC 240-47	GLASGOW	WACO	19,55	7,75	MOT150GC	GTJ120	GCT010 (GCT510)
HVCRC 250-28	GDANSK	-	19,21	5,97	MOT150GC	GTJ120	GCT010 (GCT510)
HVCRC 280-40	CASABLANCA	LAREDO	20,51	7,11	MOT150GC	GTJ123	GCT010 (GCT510)
HVCRC 320-47	OSLO	IRVING	22,4	8,76	MOT150GC	GTJ123	GCT010 (GCT510)
HVCRC 320-40	LISBON	HAWK	21,79	7,11	MOT150GC	GTJ123	GCT010 (GCT510)
HVCRC 370-47	AMSTERDAM	DOVE	23,55	7,75	MOT170GC	GTJ226	GCT010 (GCT510)
HVCRC 410-47	CORDOBA	-	24,43	7,75	MOT170GC	GTJ226	GCT010 (GCT510)
HVCRC 430-52	BRUSSELS	GROSBEEK	25,13	8,13	MOT170GC	GTJ226	GCT010 (GCT510)
HVCRC 470-60	STOCKHOLM	LUBBOCK	26,4	8,76	MOT170GC	GTJ229	GCT010 (GCT510)
HVCRC 520-60	WARSAW	CUCKOO	27,72	8,76	MOT170GC	GTJ229	GCT010 (GCT510)
HVCRC 530-71	DUBLIN	DRAKE	28,17	9,53	MOT170GC	GTJ229	GCT010 (GCT510)
HVCRC 560-60	HAMBURG	PLANO	28,62	8,76	MOT170GC	GTJ229	GCT010 (GCT510)
HVCRC 580-60	MILAN	CORPUS CHRISTI	29,1	8,76	MOT170GC	GTJ232	GCT020 (GCT520)
HVCRC 600-71	ROME	ARLINGTON	29,87	9,53	MOT170GC	GTJ232	GCT020 (GCT520)
HVCRC 640-60	VIENNA	CARDINAL	30,42	8,76	MOT170GC	GTJ232	GCT020 (GCT520)
HVCRC 680-71	BUDAPEST	FORT WORTH	31,49	9,53	MOT170GC	GTJ232	GCT020 (GCT520)
HVCRC 700-60	PRAGUE	EL PASO	31,8	8,76	MOT170GC	GTJ232	GCT020 (GCT520)
HVCRC 740-71	MUNICH	BEAUMONT	32,87	9,53	MOT170GC	GTJ233	GCT020 (GCT520)
HVCRC 750-87	WARWICK	-	33,4	10,54	MOT180GC	GTJ335	GCT020 (GCT520)
HVCRC 770-75	LONDON	SAN ANTONIO	33,42	9,78	MOT180GC	GTJ335	GCT020 (GCT520)
HVCRC 820-60	PARIS	BITTERN	34,2	8,76	MOT180GC	GTJ335	GCT020 (GCT520)
HVCRC 880-87	BORDEAUX	-	35,76	10,54	MOT180GC	GTJ338	GCT020 (GCT520)
HVCRC 950-75	ANTWERP	DALLAS	36,9	9,78	MOT180GC	GTJ338	GCT020 (GCT520)
HVCRC 1020-75	MADRID	LAPWING	38,18	9,78	MOT180GC	GTJ341	GCT030 (GCT530)
HVCRC 1160-79	CHUKAR	CHUKAR	40,74	10,03	MOT180GC	GTJ341	GCT030 (GCT530)

SELF-GRIPPING CLAMPS

These clamps can be used on ropes, conductors, or optical ground wires. Interchangeable jaws of **different material and dimensions** allow the user to adapt a few models of clamps to a vast array of solutions.

The body is made of **high strength hot forged steel**, to minimize the ratio between weight and working load, and the galvanization treatment on the surface protects from oxidation ensuring safety and efficiency to every job.

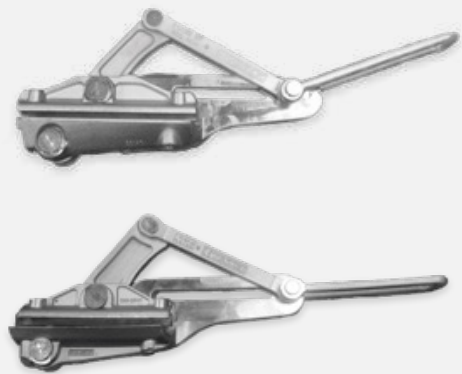

RADIAL LOCKING CLAMPS

Can be used whenever a conductor has to be held in position for a long time. It is made of a series of hinged elements, which can be locked by nuts, the number of elements can go from a **minimum of 4 to a maximum of 20**, depending on the working load. A special hook is provided at one end.

The galvanization treatment on the surface **protects from oxidation** ensuring safety and efficiency to every job.

The interchangeable jaws are made of aluminum., This kind of clamps are suggested to be used with armor rod, avoiding any conductor damage.



SOCK JOINTS

Tesmec Sock joints are **handcrafted in Italy** by using strands made with single galvanized wire.

Thanks to a specific formation, **they are a reliable solution** that grants excellent flexibility property and performance.





EPSILON COMPOSITE SAS
5 Route de Hourtin
33340 Gaillan-en-Médoc - FRANCE
Phone: +33 (0)556 734 774

www.epsilon-cable.com
contact@epsilon-cable.com



Tesmec S.p.A.
Via Zanica 17/O
24050 Grassobbio (BG)
Tel. 035 42.32.911

www.tesmec.com
info@tesmec.com

